

Dublin Slim

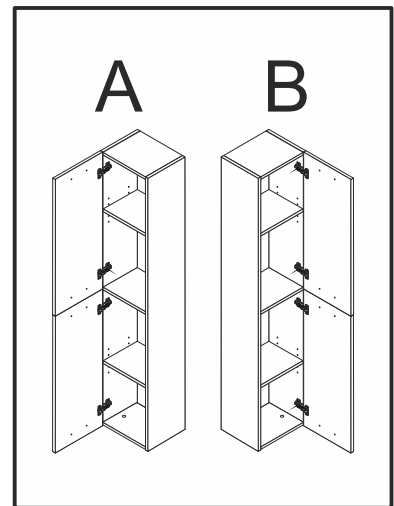

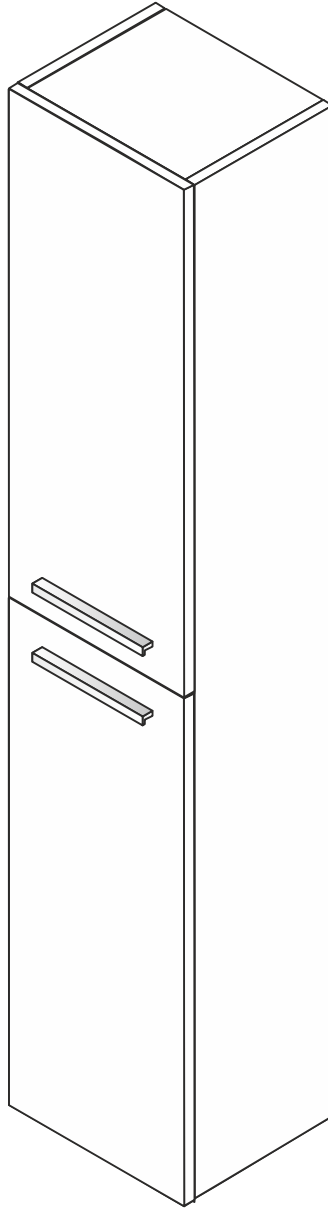

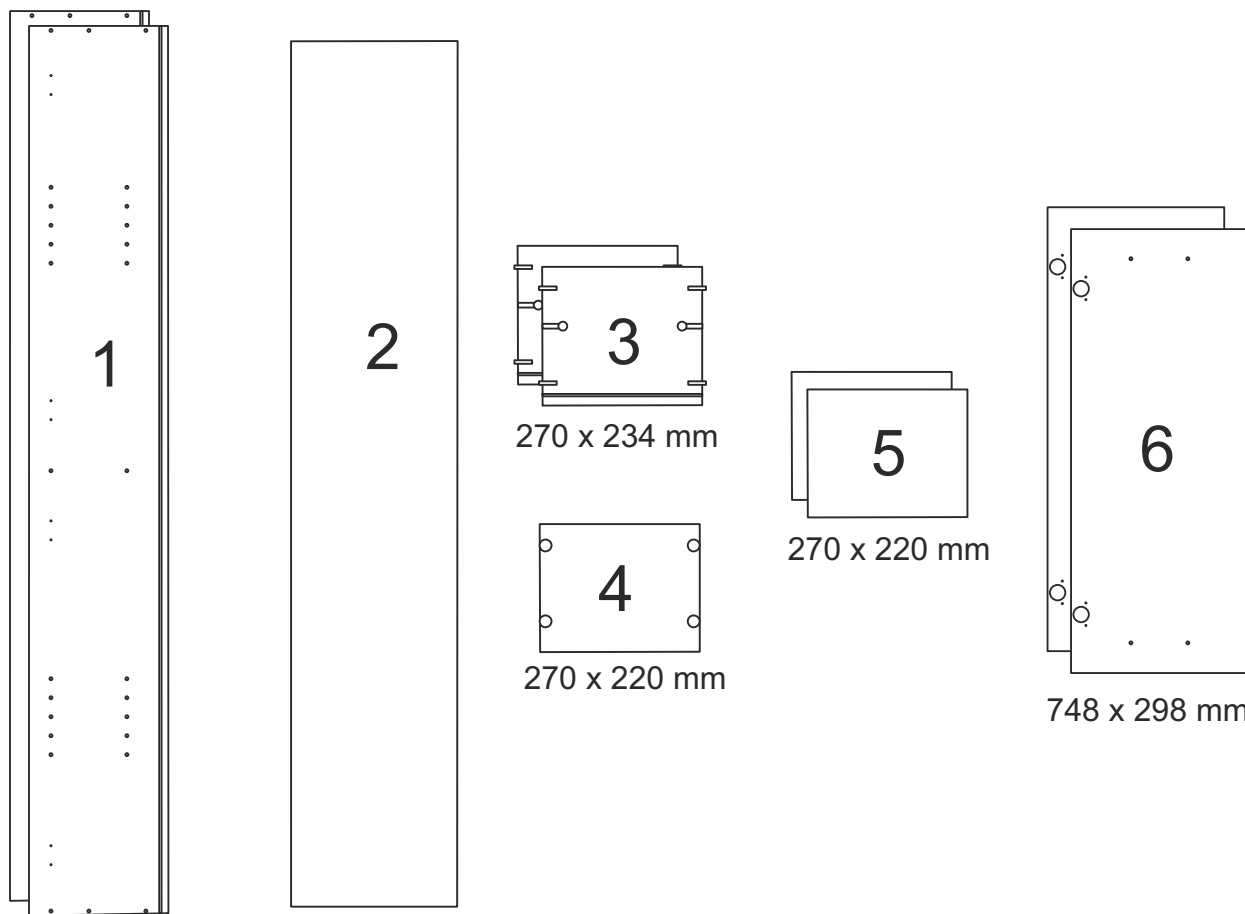

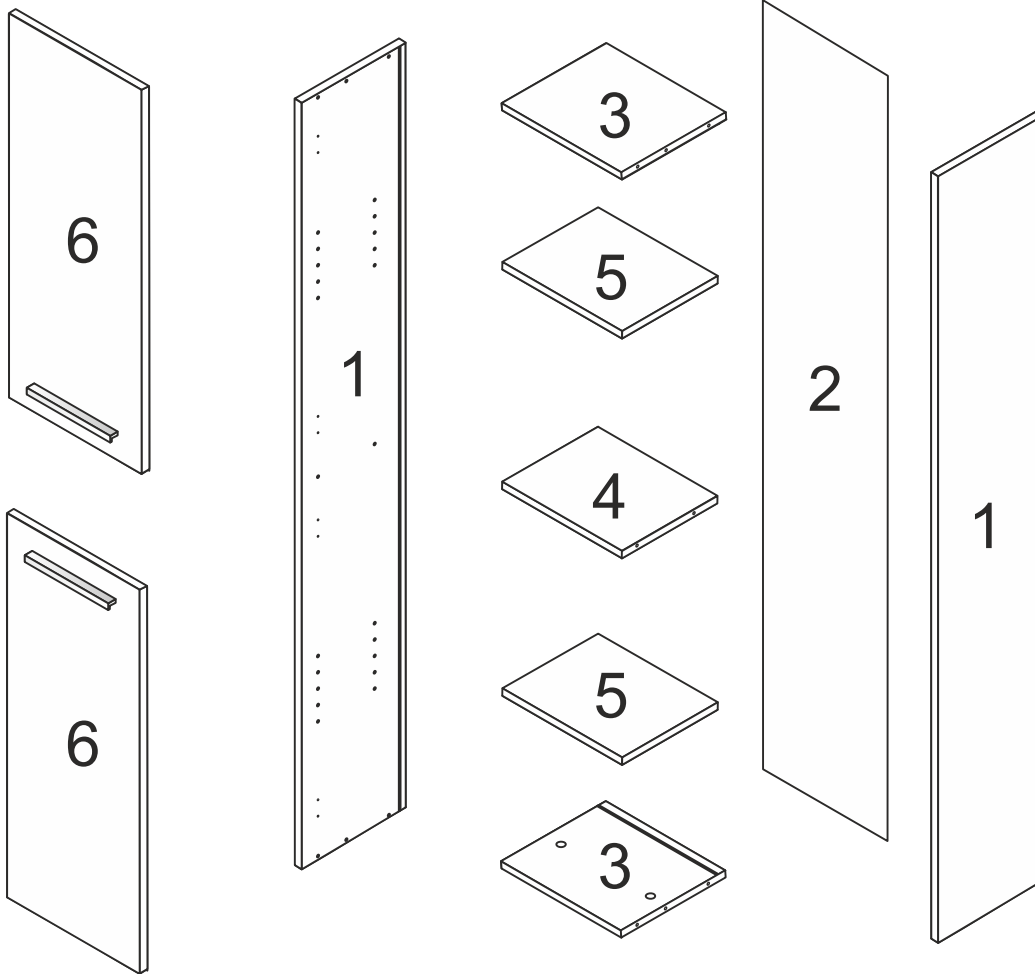

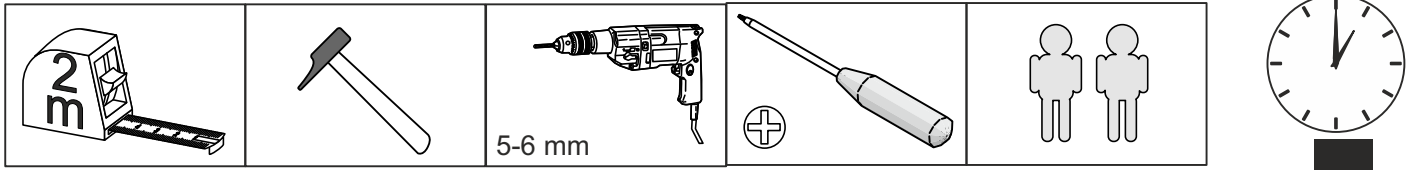
RAVENNA No1

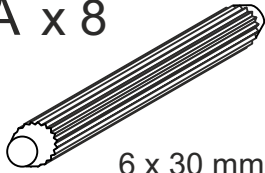

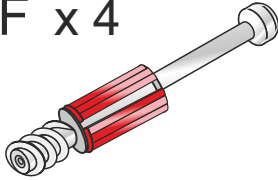
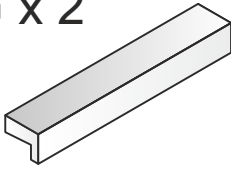
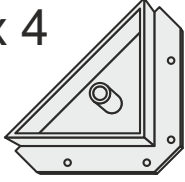
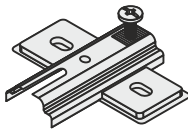

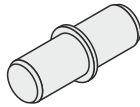
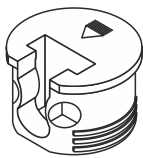
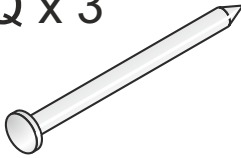

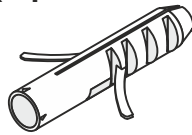
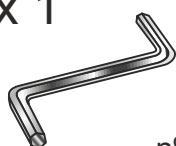
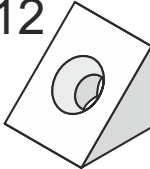

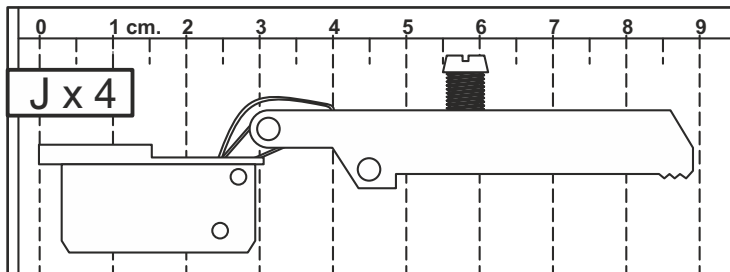

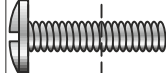
COLUMNA BAÑO - BATH WALL CUPBOARD - ARMOIRE À SUSPENDRE
ARMARIO PAREDE - COLONNA BAGNO - ΣΤΗΛΗ ΜΠΑΝΙΟΥ

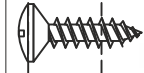



A x 8  6 x 30 mm	E x 4 	F x 4 	G x 2 
H x 4 	K x 4 	L x 4  5 mm	N x 8 
P x 4 	Q x 3 	V x 4  15 mm	W x 4 
X x 1  n° 4	Y x 12 		

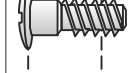

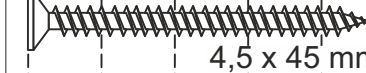
	0	1 cm.	2	3	4
	D x 4				
					M4 x 18 mm
	R x 16				
					4 x 16 mm
	S x 12				
					3.5 x 20 mm
	T x 12				
					3,5 x 30 mm
	U x 4				
					M8 x 13 mm
	Z x 4				
					4,5 x 45 mm

1

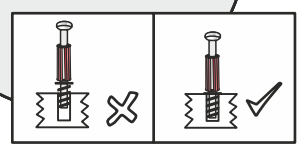
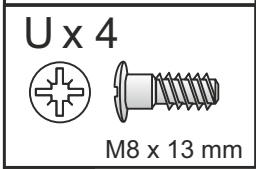
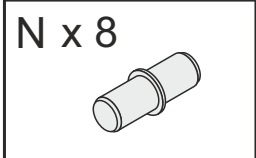
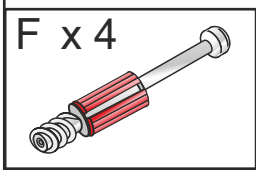
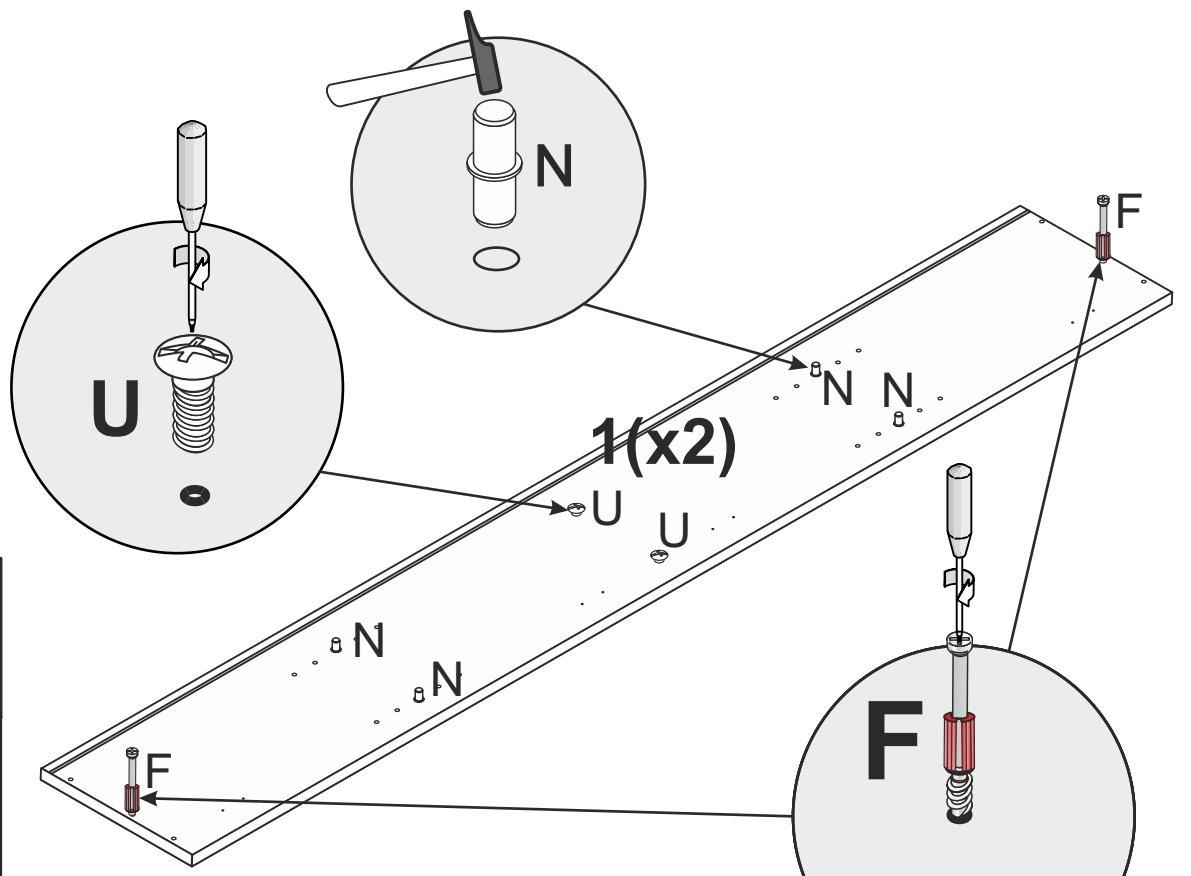

2

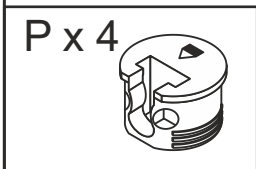
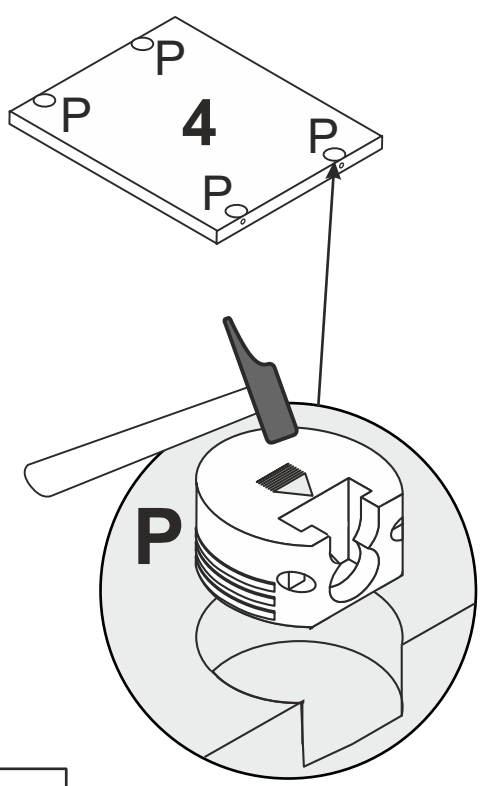

3

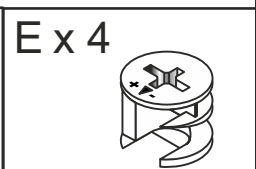
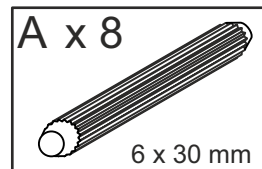
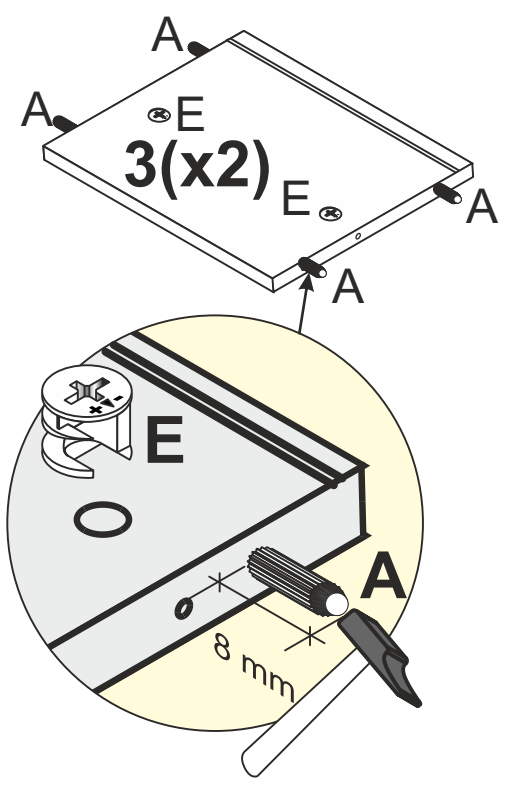

4

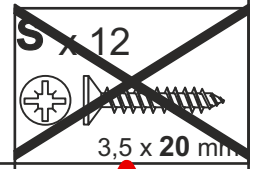
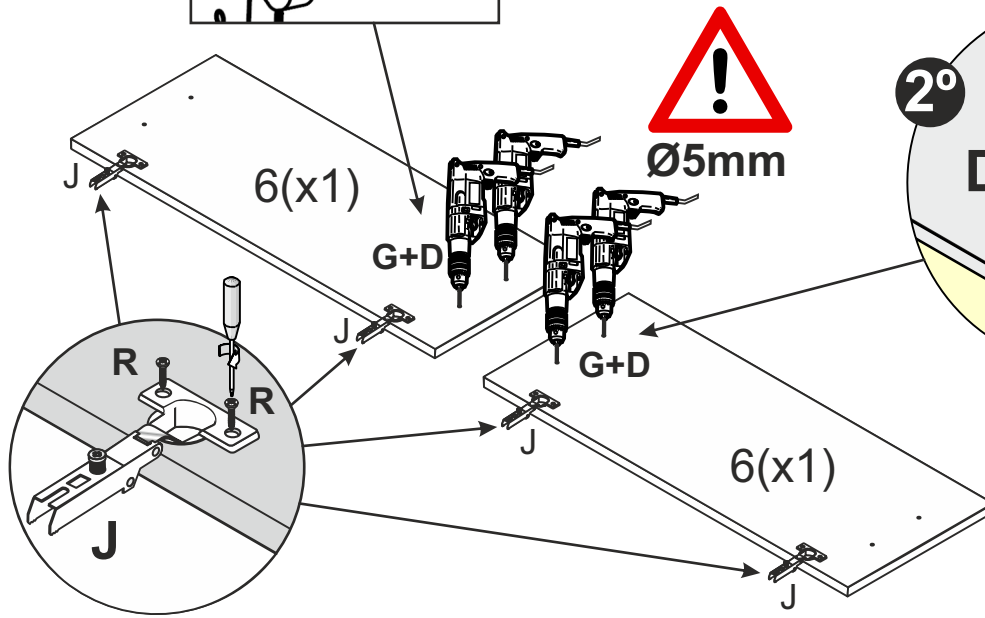
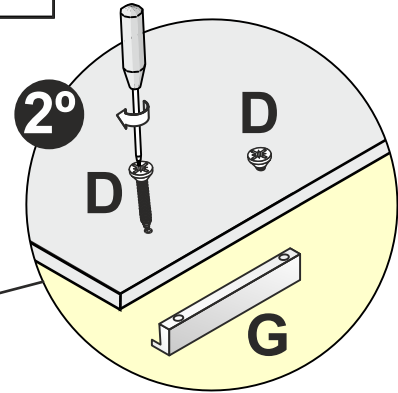
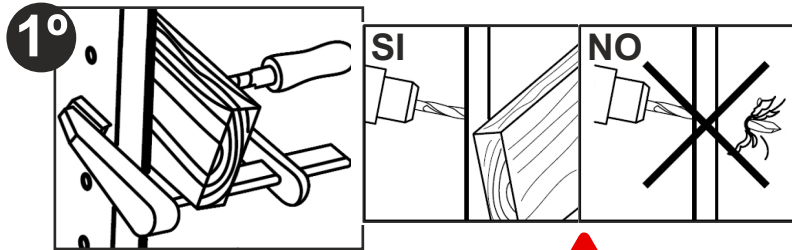

<p>5 mm</p>	<p>D x 4</p> <p>M4 x 18 mm</p>	<p>G x 2</p>	<p>J x 4</p>	<p>R x 8</p> <p>4 x 16 mm</p>	
-------------	--------------------------------	--------------	--------------	-------------------------------	--

5

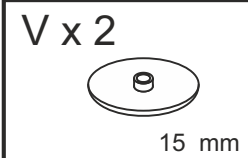
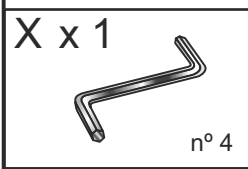
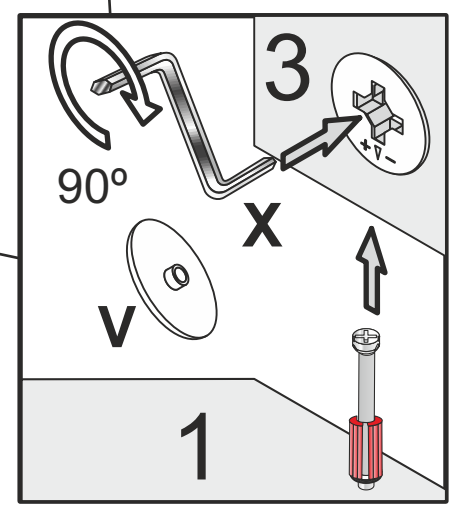
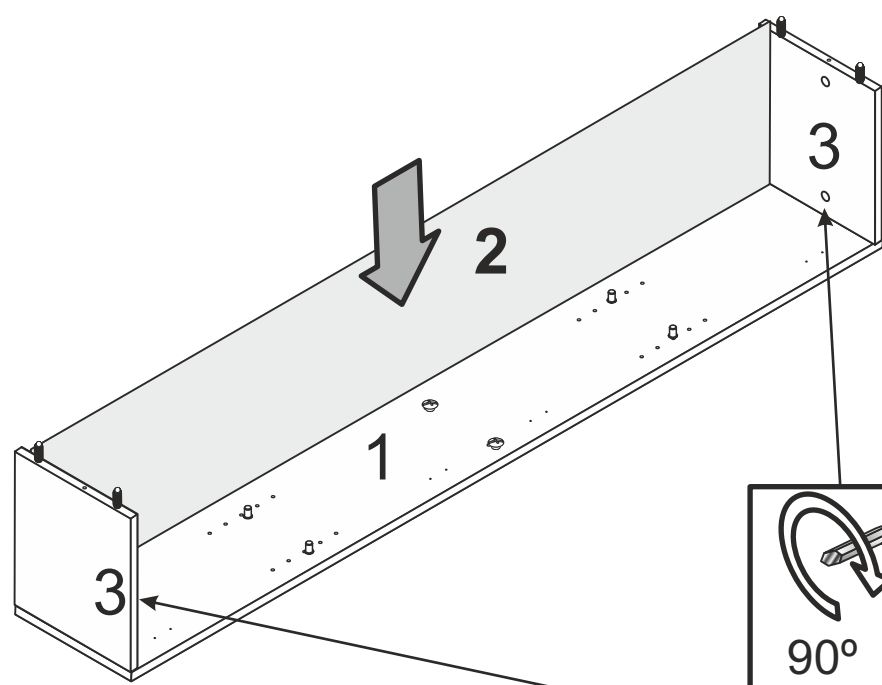

6

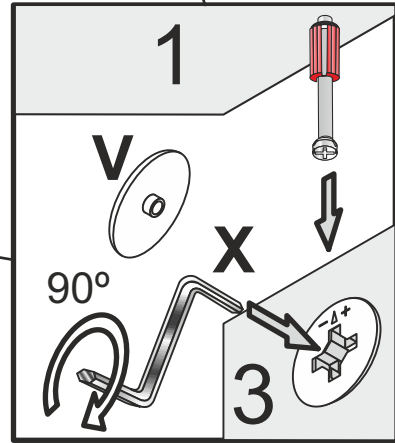
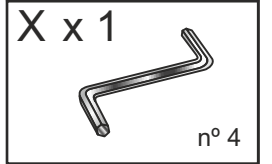
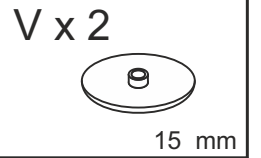
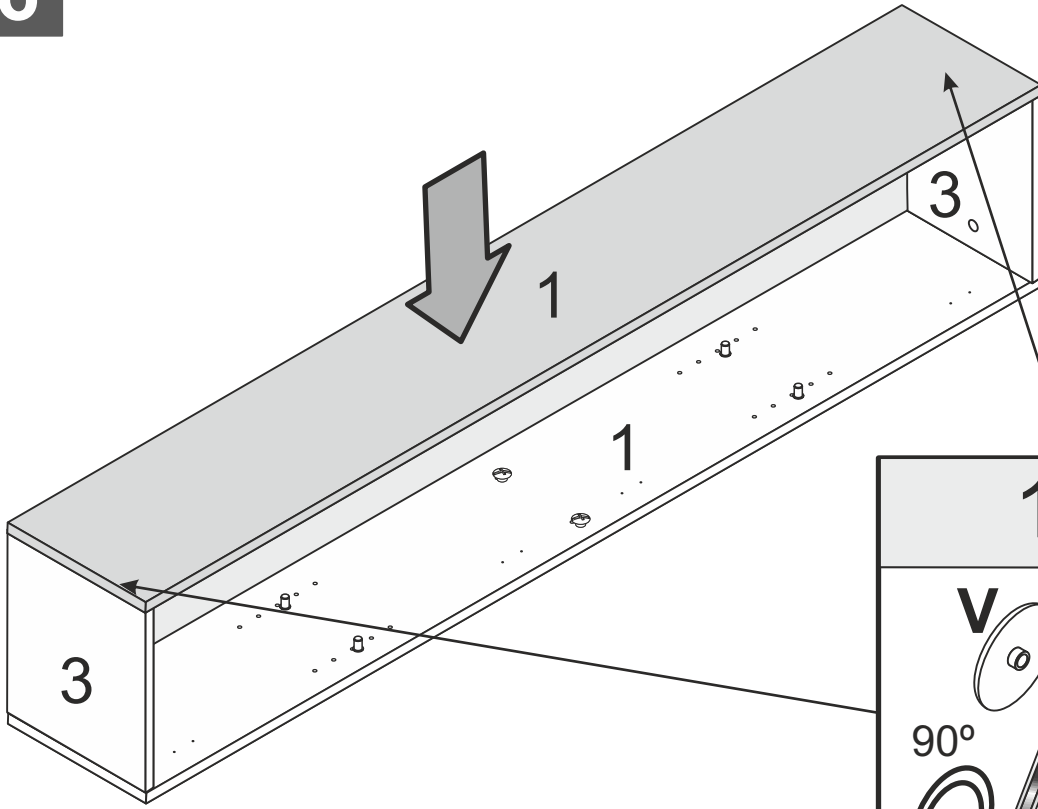

7

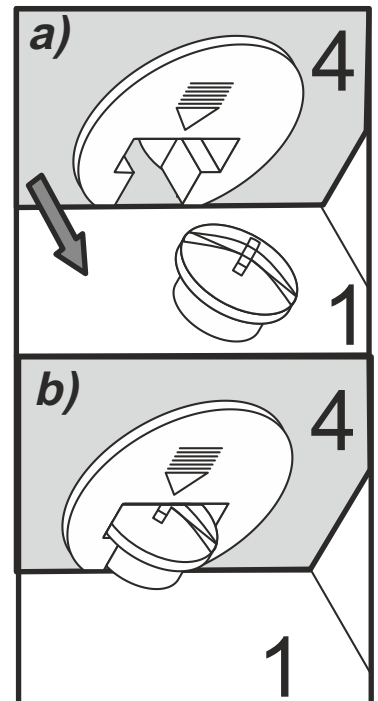
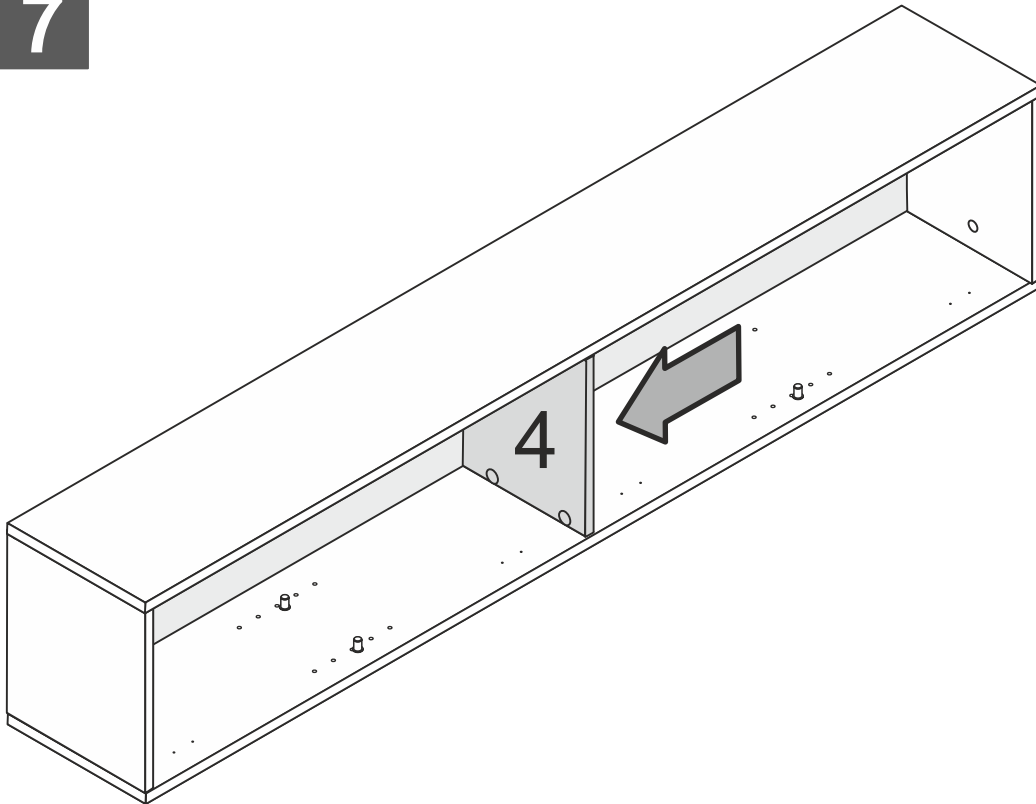

8

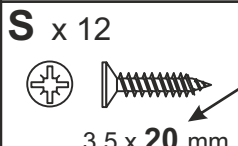
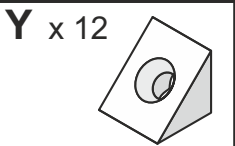
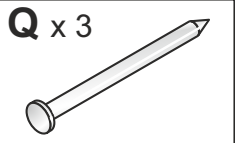
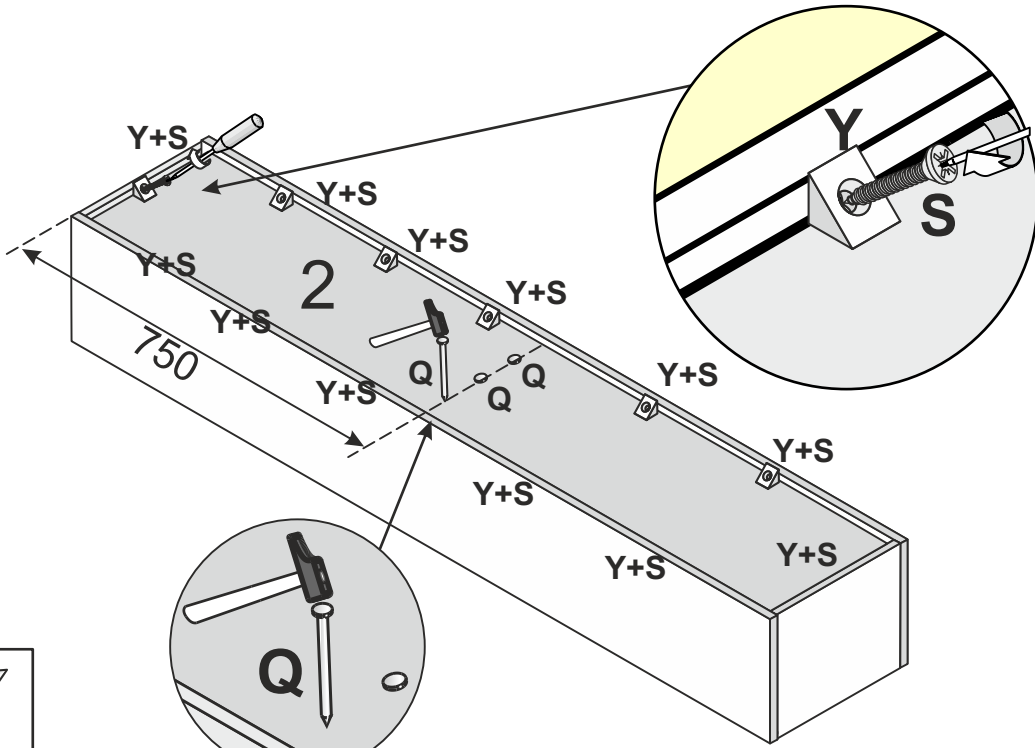

9

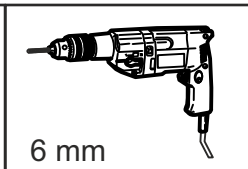
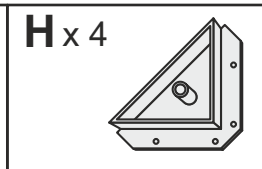
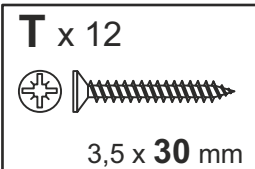
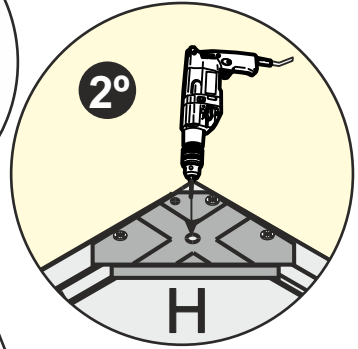
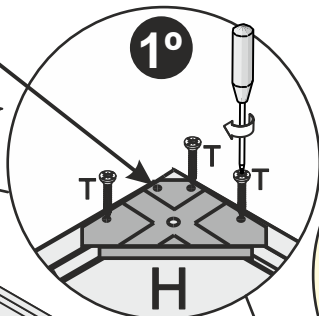
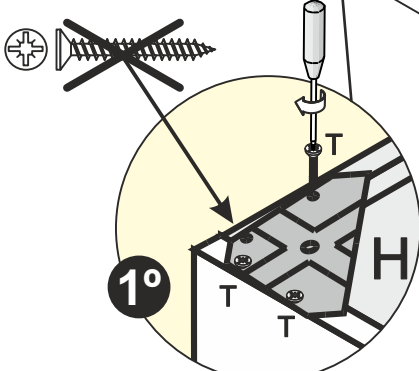
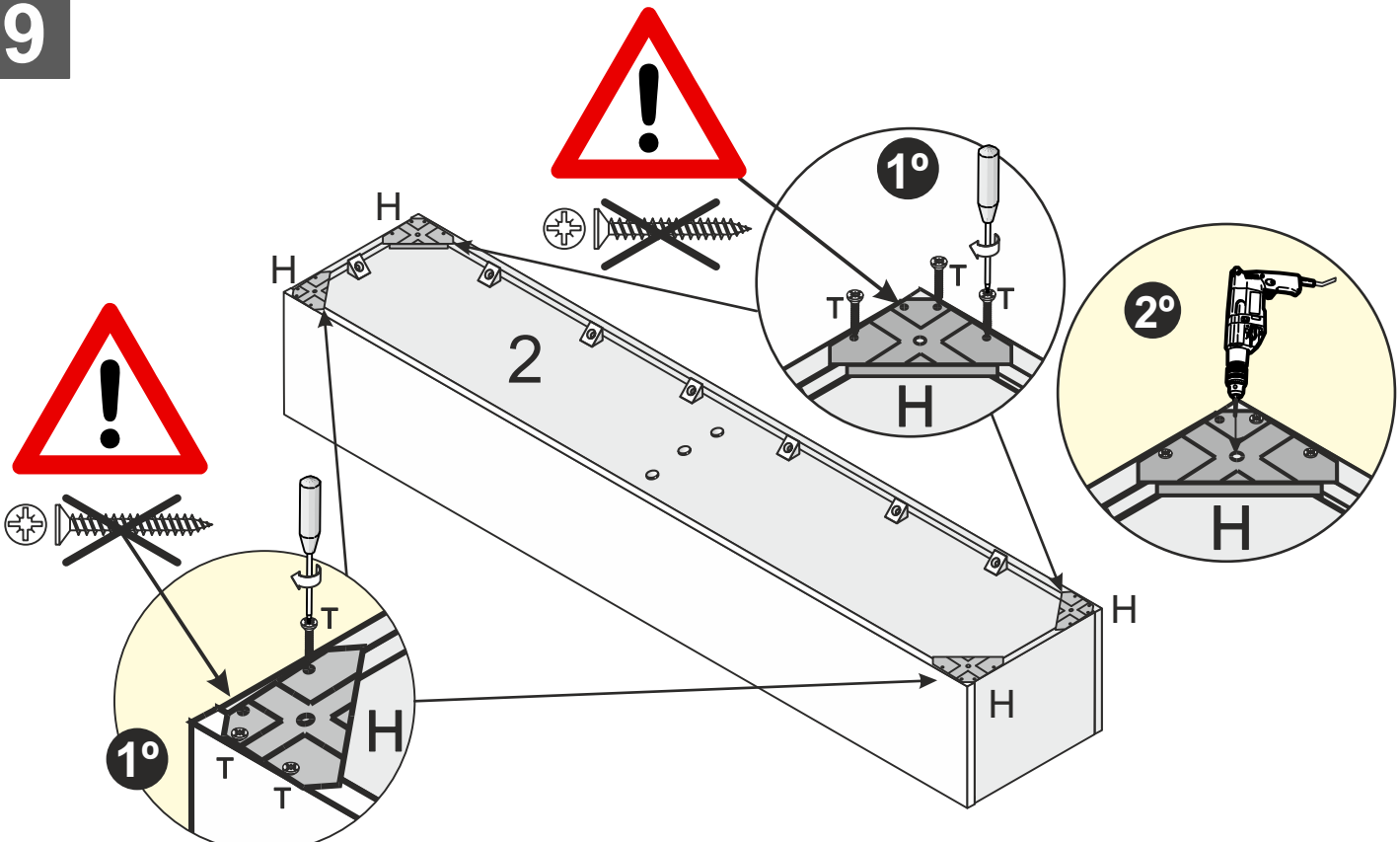

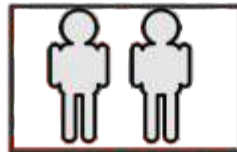

- ES** · USE HERRAJES ADECUADOS PARA EL MATERIAL DE LAS PAREDES DE SU CASA
- EN** · USE FIXING DEVICES SUITABLE FOR THE WALLS IN YOUR HOME
- FR** · UTILISEZ DES FIXATIONS ADAPTÉES AU MATÉRIAU DU MUR
- PT** · UTILIZE FERRAGENS ADEQUADAS ÀS PAREDES DA SUA CASA
- IT** · USA SISTEMI DI FISSAGGIO ADATTI ALLE PARETI DELLA TUA CASA
- DE** · BEFESTIGUNGSBESCHLÄGE BENUTZEN, DIE FÜR DIE HEIMISCHEN WÄNDE GEEIGNET SIND
- GR** · ΧΡΗΣΙΜΟΠΟΙΗΣΤΕ ΕΞΑΡΤΗΜΑΤΑ ΣΤΕΡΕΩΣΗΣ ΚΑΤΑΛΛΗΛΑ ΓΙΑ ΤΟΥΣ ΤΟΙΧΟΥΣ ΤΟΥ ΣΠΙΤΙΟΥ ΣΑΣ

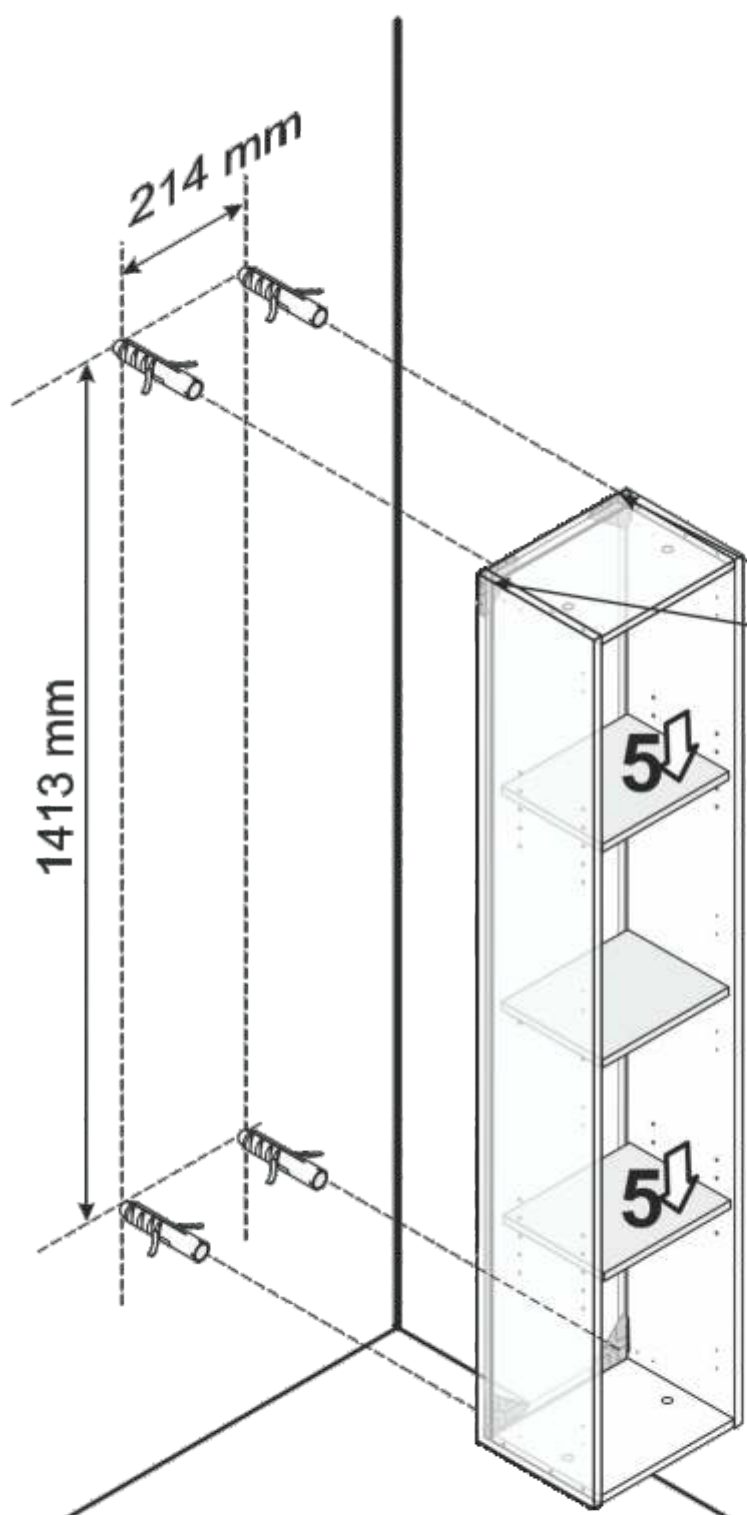

	1)
6 mm 	2)
 W	3)
 Z	4)

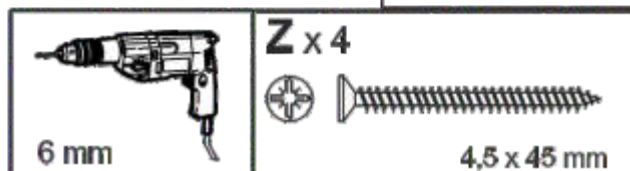
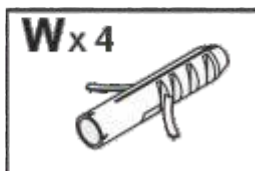

11

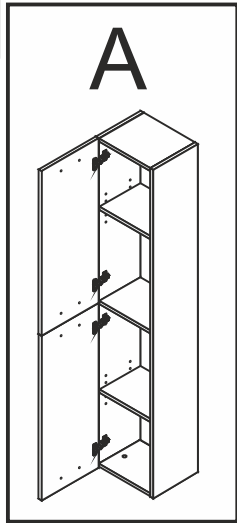

R x 8



4 x 16 mm

K x 4

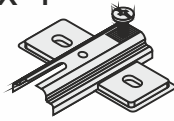

~~S x 12~~



~~3,5 x 20 mm~~

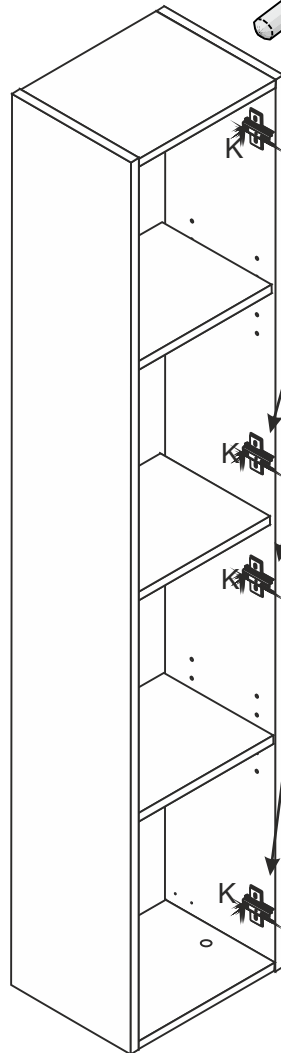
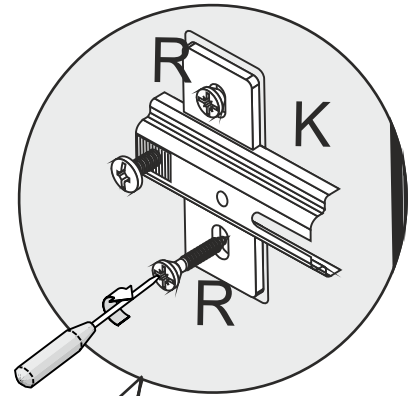
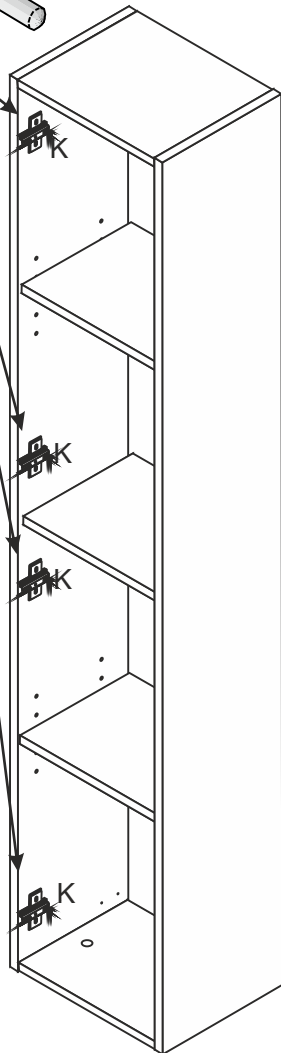
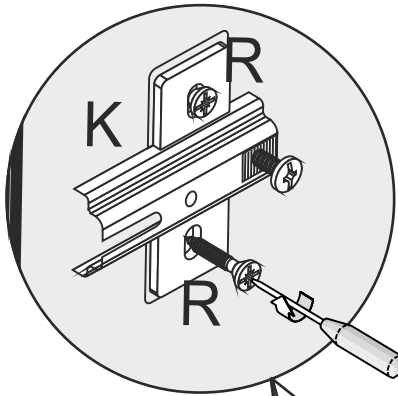
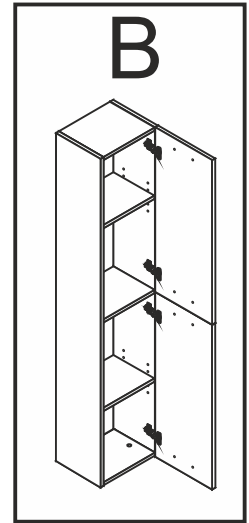

12

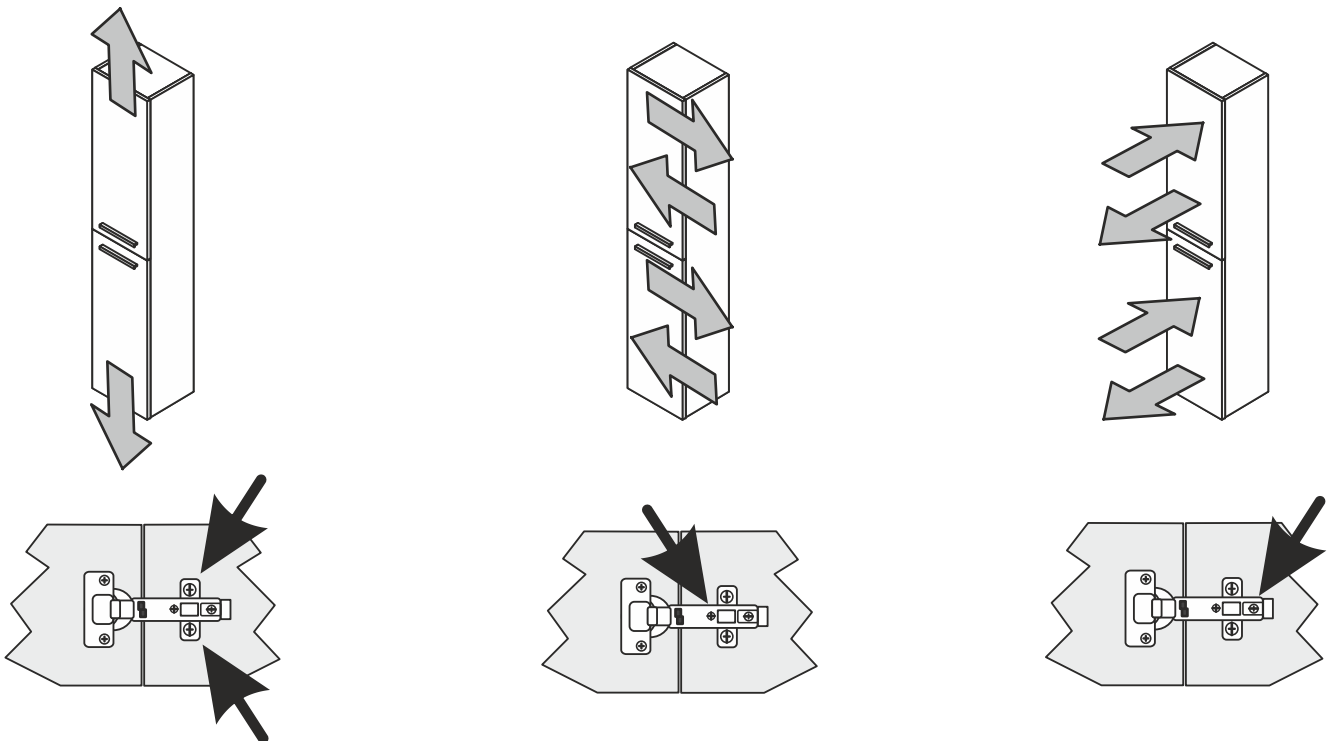
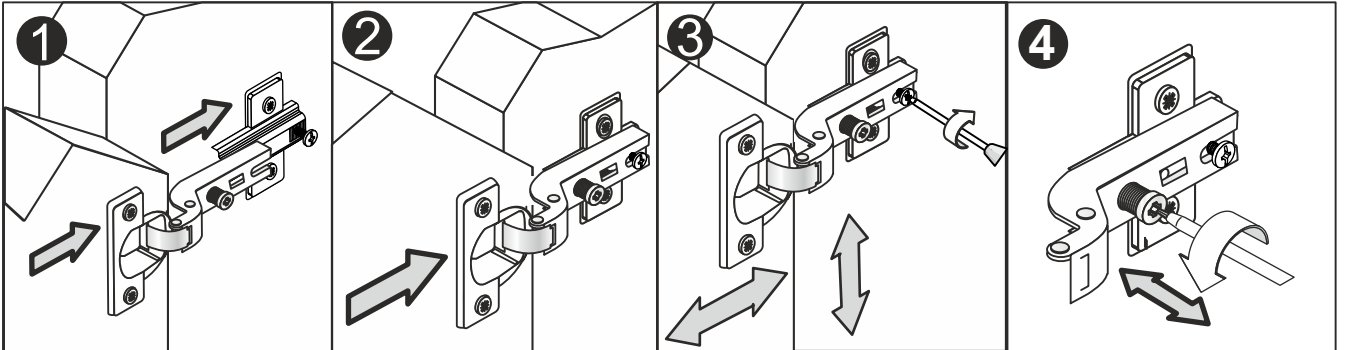
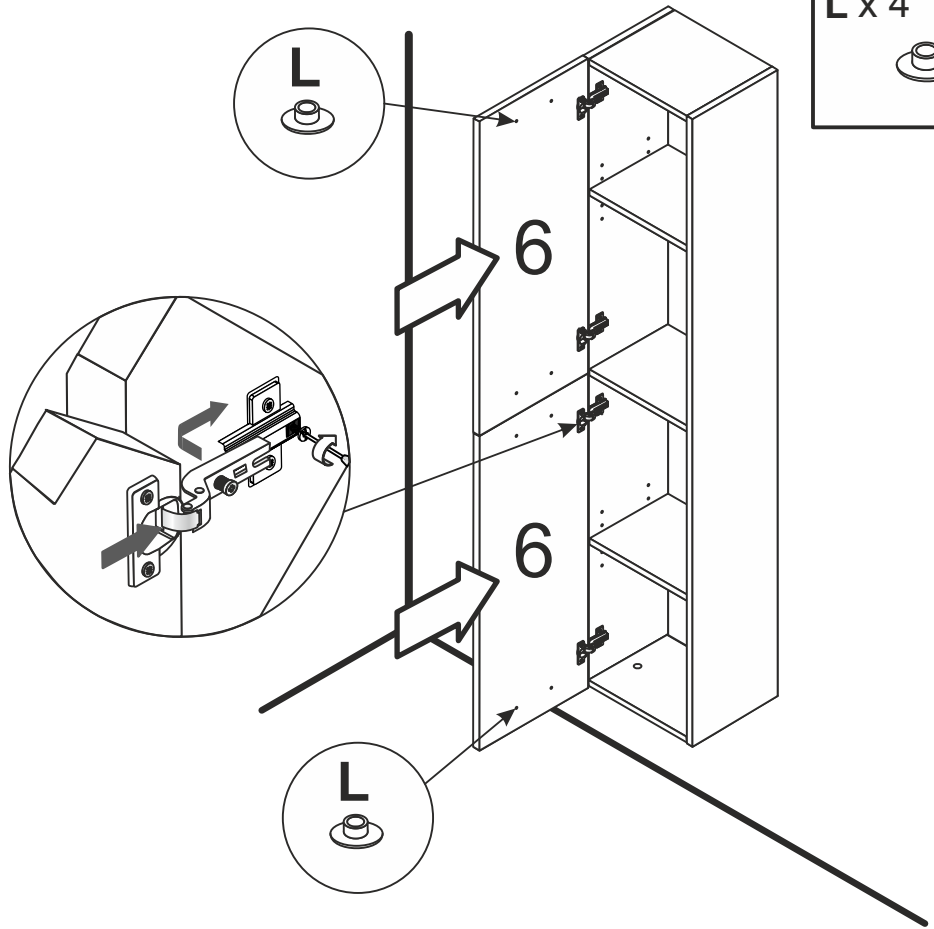
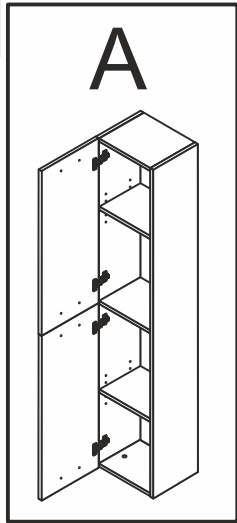

ES

INFORMACIÓN IMPORTANTE SOBRE EL MONTAJE DE LOS MUEBLES EN LA PARED

- Una vez montado según las instrucciones de montaje, el mueble está listo para montar en la pared. Un montaje de pared incorrecto puede ocasionar la caída del mueble y, por tanto, graves daños materiales y/o personales. RAVENNA SA no se hace responsable de daños personales o materiales ocasionados por un montaje de pared incorrecto.
- La pared debe tener la resistencia necesaria para el montaje de los muebles en pared, no se debe realizar el montaje en paredes sin primero asegurarse de que la pared tenga la resistencia requerida o haya sido reforzada adecuadamente. Utilice herrajes adecuados para el material de las paredes de su casa. Póngase en contacto con su ferretero local que le asesorará en la elección del sistema de tornillos correcto para el tipo de material de la pared.

EN

IMPORTANT INFORMATION ABOUT THE ASSEMBLING OF WALL HUNG UNITS

- Once the furniture has been assembled according to the instructions, it's ready to get wall hanged. The furniture can drop down if it hasn't been mounted correctly what can also cause serious material and/or personal damage. RAVENNA SA is not responsible for personal or material damages caused by an incorrect mounting of the wall hung unit.
- Ensure that the wall is resistant enough to carry the weight of the furniture or has been reinforced suitably. Use appropriate hardware for the material of the walls of your house. Contact your local technician who will advise you in choosing the right screw system for the type of material of your wall.

FR

INFORMATIONS IMPORTANTES CONCERNANT LE MONTAGE MURAL DU MOBILIER

- Une fois le meuble monté, après avoir suivi les instructions de montage, il s'agit de fixer le meuble au mur en toute sécurité. En cas de montage mural incorrect, le meuble risque de basculer et de tomber par terre; entraînant ainsi de graves dommages matériels et/ou blessures. RAVENNA SA décline toute responsabilité en cas de blessures ou de dommages matériels pour un accrochage mural incorrect.
- Le mur doit avoir la résistance nécessaire pour la fixation murale. Avant de fixer les meubles au mur il faut impérativement vérifier que le mur possède la résistance requise ou qu'il a été suffisamment renforcé. Le choix de la visserie à utiliser pour la fixation murale utilisée dépend de votre type de mur. Utilisez des fixations adaptées. Contactez votre quincaillier local de confiance pour sélectionner la visserie à utiliser pour la fixation murale.

PT

INFORMAÇÕES IMPORTANTES SOBRE A MONTAGEM DOS MOVÉIS NA PAREDE

- Uma vez montado de acordo com as instruções de montagem, o mobiliário está pronto para ser montado na parede. A montagem incorreta na parede pode causar a queda do mobiliário e, portanto, sérios danos materiais e / ou pessoais. RAVENNA SA não se faz responsável por danos pessoais ou materiais causados por uma montagem incorreta na parede.
- A parede deve ter a resistência necessária para a montagem dos móveis na parede, não deve ser montada nas paredes sem primeiro garantir que a parede tem a força necessária ou foi adequadamente reforçada. Use o hardware adequado para o material das paredes da sua casa. Entre em contato com o ferrageiro local, que irá aconselhá-lo a escolher o sistema de parafuso direito para o tipo de material de parede.

IT

INFORMAZIONE IMPORTANTE RIGUARDO IL FISSAGGIO ALLA PARETE DEL MOBILE

- Secondo le istruzioni, una volta montato il mobile, sarà pronto per essere fissato alla parete. Un fissaggio alla parete non corretto può ocasionare la caduta del mobile e conseguenti gravi danni materiali e/o a persone. RAVENNA SA non si assume la responsabilità di possibili danni personali o materiali causati da un incorretto fissaggio del mobile alla parete.
- La parete deve avere la resistenza necessaria per sopportare il peso del mobile, non si deve realizzare il fissaggio in una parete senza anteriormente verificare la reale capacità di carico, o se non si è adeguatamente rinforzata per sostenere il peso del mobile. Per il fissaggio, utilizza la ferramenta più adatta al materiale della parete. Nel caso di dubbi, chiedi consiglio al Suo negozio ferramenta di fiducia, sulla scelta delle viti e tasselli più adatti al tipo di materiale della parete.

DE

WICHTIGE INFORMATIONEN ZUR MONTAGE VON HÄNGEMÖBELN

- Nach der Montage gemäß der Montageanleitung sind die Möbel bereit für die Befestigung an der Wand. Eine falsche Befestigung kann zum Fall des Möbels führen, was schwerwiegende Material- und / oder Personenschäden zur Folge haben kann. RAVENNA SA haftet nicht für Personen- oder Sachschäden, die durch eine inkorrekte Montage an der Wand verursacht wurden.
- Die Wand muss den notwendigen Widerstand für die Montage der Möbel an der Wand haben. Die Möbel sollten nicht an Wände montiert werden, ohne vorher sicherzustellen, dass die Wand die erforderliche Festigkeit hat oder ausreichend verstärkt wurde. Verwenden Sie geeignete Hardware für das Material der Wände Ihres Hauses. Wenden Sie sich an Ihren örtlichen Eisenwarenhändler, der Sie bei der Auswahl des richtigen Schraubensystems für Ihr Wandmaterial berät.

GR

ΣΗΜΑΝΤΙΚΕΣ ΠΛΗΡΟΦΟΡΙΕΣ ΣΧΕΤΙΚΑ ΜΕ ΤΗ ΣΤΗΡΙΞΗ ΕΠΙΠΛΩΝ ΣΕ ΤΟΙΧΟ

- Αφού συναρμολογήσετε αυτό το προϊόν σύμφωνα με τις οδηγίες συναρμολόγησης, μπορείτε να το στηρίξετε σε τοίχο. Η εσφαλμένη στήριξη μπορεί να οδηγήσει στην πτώση του προϊόντος από τον τοίχο, προκαλώντας σοβαρές υλικές ζημιές και/ή τραυματισμούς ατόμων. Η εταιρεία RAVENNA MON. ΑΕ δεν ευθύνεται για προσωπικές ή υλικές βλάβες που προκύπτουν από εσφαλμένη στήριξη.
- Ο τοίχος πρέπει να έχει την απαραίτητη αντίσταση για τη στήριξη των επίπλων στον τοίχο, η στήριξη στους τοίχους δεν πρέπει να πραγματοποιείται χωρίς να εξασφαλίζεται πρώτα ότι το τοίχωμα έχει την απαιτούμενη αντοχή ή έχει ενισχυθεί επαρκώς. Χρησιμοποιήστε κατάλληλο υλικό στήριξης για το υλικό των τοίχων του σπιτιού σας. Επικοινωνήστε με κάποιον ειδικό για τη σωστή επιλογή των βιδών σε σχέση με το υλικό του τοίχου.

ES

MONTAJE

- Preparar las piezas que constituyen el mueble.
- Reagrupar y contar el herraje.
- Preparar las herramientas necesarias.
- Preparar la zona de montaje.
- Realizar el montaje sobre una moqueta para evitar rayar el mueble.
- No forzar nunca los ensamblajes.

USO

- No colocar cerca de fuentes de calor.
- Mueble apto para uso doméstico. Ubicación en el interior de la vivienda.
- Se recomienda, tras la instalación del mueble, airear la habitación donde se encuentre.

MANTENIMIENTO Y LIMPIEZA

- Limpiar con un paño humedecido con una solución jabonosa.
- Secar con un paño limpio.
- No utilizar paños, trapos o productos de limpieza que puedan rayar la superficie del mueble

IT

INSTALLAZIONE

- Prerapare i pezzi che costituiscono il mobile.
- Raggruppare e contare la ferramenta.
- Preparare gli attrezzi necessari.
- Preparare una zona per il montaggio.
- Realizzare il montaggio sopra un tappeto per evitare che il mobile si graffi.
- Non forzare mai l'assemblaggio.

USO

- Non collocare vicino a fonti di calore.
- Mobile adatto ad un uso domestico. Adatto a uso interno.
- Dopo l'installazione del mobile, si consiglia di arieggiare la stanza.

ISTRUZIONI PER LA PULIZIA

- Pulire con un panno umido e un detergente neutro.
- Asciugare con un panno pulito.
- Non utilizzare panni, trappi o prodotti di pulizia che possano graffiare la superficie del mobile.

EN

ASSEMBLE

- Prepare the different pieces of the furniture.
- Regroup and count the hardware.
- Prepare the necessary tools.
- Prepare the area to assemble the furniture.
- Assemble the furniture on a carpet to avoid any damages.
- Do not force the hardware.

USE

- Do not place the furniture near the heat sources.
- It's suitable for domestic use, keep it indoors.
- It is recommended, after the assembling to air the room

MAINTENANCE AND CLEANING

- Clean it with a damp cloth with mild cleaners.
- Dry it with a clean cloth.
- Do not use cloths or cleaning products that could damage the surface of the furniture.

DE

MONTAGEHINWEISE

- Sortieren und identifizieren Sie die Einzelteile.
- Überprüfen Sie die Anzahl der einzelnen Beschlagteile.
- Legen Sie das notwendige Werkzeug bereit.
- Machen Sie einen Montagebereich frei.
- Montieren Sie das Möbelstück auf einem ebenen, weichen und sauberen Untergrund.
- Überziehen Sie die Beschlagteile nicht.

GEBRAUCHSHINWEISE

- Platzieren Sie das Möbelstück niemals neben Wärmequellen.
- Das Möbelstück ist ausschließlich für den Gebrauch im Haus geeignet.
- Es wird empfohlen, nach dem Aufbau des Möbelstücks, den Raum in dem es sich befindet zu lüften.

REINIGUNG UND PFLEGE

- Mit einem feuchten Tuch mit milder Seifenlösung abwischen.
- Trocken nachwischen.
- Für die Reinigung verwenden Sie bitte ein weiches Tuch und keinesfalls scharfe oder ätzende Reinigungsmittel.

FR

MONTAGE

- Identifier les différents panneaux.
- Regrouper et compter la quincaillerie.
- Munissez-vous de l'outillage nécessaire.
- Aménagez-vous une zone de montage. La moquette ou une couverture protégera des rayures.
- Ne jamais forcer le montage.

USAGE

- Ne pas placer près des sources de chaleur.
- Meuble apte pour l'usage domestique, on peut le placer à l'intérieur de la maison.
- Il est recommandé, après l'installation du meuble dans son logement, d'aérer fréquemment la pièce concernée.

ENTRETIEN ET NETTOYAGE

- Nettoyer avec un chiffon humide et une solution savonneuse.
- Essuyer avec un chiffon sec et propre.
- N'utiliser pas de chiffons ou des produits de nettoyage qui puissent rayer la surface du meuble.

GR

ΣΥΝΑΡΜΟΛΟΓΗΣΗ

- Προετοιμάστε τα μέρη του επίπλου.
- Ομαδοποιείστε και μετρήστε τα μικρά μέρη (βίδες, μεντεσέδες...).
- Προετοιμάστε τα εργαλεία που θα χρειαστείτε.
- Προετοιμάστε το χώρο συναρμολόγησης.
- Μια μοκέτα θα προφυλάξει το έπιπλο από γρατζουνιές.
- Μην ασκείτε πίεση στα κομμάτια.

ΧΡΗΣΗ

- Μην το τοποθετείτε κοντά σε πηγή θερμότητας
- Το έπιπλο έχει κατασκευαστεί για οικιακή χρήση, τοποθετήστε το στο εσωτερικό της οικίας.
- Συνιστάται, μετά τη συναρμολόγηση να αερίσετε το δωμάτιο.

ΣΥΝΤΗΡΗΣΗ ΚΑΙ ΚΑΘΑΡΙΣΜΟΣ

- Καθαρίστε το με ένα πανί μουσκεμένο σε ένα ελαφρύ απορρυπαντικό.
- Στεγνώστε το με ένα καθαρό πανί.
- Μην χρησιμοποιείτε πανιά και καθαριστικά που μπορούν να καταστρέψουν την επιφάνεια.

PT

MONTAGEM

- Prepare as peças que compõem o móvel.
- Reagrupe e contar as ferragens.
- Prepare as ferramentas necessárias.
- Prepare a área para a montagem.
- Efectuar a montagem sobre uma alcatifa para evitar arranhar o móvel.
- Não forçar nunca a ensambladura.

USO

- Não colocar perto de fontes de calor.
- Móvel apto para o uso doméstico. Colocação no interior da vivenda.
- Após a instalação dos móveis, é recomendável ventilar a sala onde está localizado.

MANUTENÇÃO E LIMPEZA

- Limpe bem com um pano humedecido numa solução detergente suave.
- Seque bem com um pano limpo.
- Não utilizar panos, trapos ou produtos de limpeza que possam riscar a superfície do móvel.

GARANTÍA - GUARANTEE - GUARANTIE - GARANTIA - GARANZIA - GARANTIE - GARANTISI - ΕΓΓΥΗΣΗ

ES · Fabricado en U.E. SPAIN - el cual garantiza este producto por un periodo de **3 años** a partir de la fecha de compra, contra todo defecto de fabricación.

- Esta garantía no ampara los defectos producidos por un mal montaje, utilización indebida o mal uso del mueble.
- Es imprescindible conservar el **ticket** de compra y facilitar el **Nº de Control de Calidad (Q.C.)** para cualquier consulta o reclamación.

EN · Manufactured in Spain - Guarantee of **3 years** from date of purchase against any production defects.

- The Guarantee does not cover the defects produced by poor or incorrect assembly or misuse of the furniture.
- It is essential to keep the purchase **receipt** and provide the **Quality Control Number (Q.C.)** for any queries or claim.

FR · Fabriqué en UE Espagne – Celui ci garantie ce produit pour une période de **3 ans** à partir de la date d'achat, contre tout défaut de fabrication.

- Cette garantie ne couvre pas les défauts résultants d'un mauvais montage, d'une utilisation indue ou d'un mauvais usage du produit.
- Il est indispensable de garder le **ticket** ou facture d'achat et de communiquer le **Numéro de Control Qualité (Q.C.)** pour une quelconque demande ou réclamation.

PT · Fabricado U.E. ESPANHA - que garante este produto por um período de **3 anos** a partir da data de compra; contra defeitos de fabricação.

- Esta garantia não cobre defeitos causados pela montagem incorreta, uso indevido ou mau trato do produto.
- É essencial manter o **recibo** de compra e facilitar o **Nº Controle de Qualidade (Q.C.)** para quaisquer dúvidas ou reclamações.

IT · Prodotto in Spagna. Garantito **3 Anni** dalla data di acquisto contro ogni difetto di produzione.

- La garanzia non copre difetti o danni dovuti a montaggio scorretto o ad uso improprio del prodotto.
- La garanzia é valida solo in presenza dello **sccontrino di acquisto** e del **Nº di controllo qualità (Q.C.)** presente nella confezione.

DE · Hergestellt in Spanien. - Garantie von **3 Jahren** ab kaufdatum gegen jede störung der produktion.

- Diese Garantie gilt nicht für Mängel, die durch unsachgemäße Installation, unsachgemäße Behandlung und Verwendung des Geräts verursacht werden.
- Unentbehrlich, um den **Kauf Ticket** behalten und erleichtern die Anzahl der **Qualitätskontrollzahl (Q.C.)** für alle zu konsultieren oder Anspruch.

GR · Κατασκευάζεται στην Ισπανία. - Η εγγύηση ισχύει για **3 έτη** από την αρχική ημερομηνία αγοράς και καλύπτει ελαττωματικά υλικά ή ελαττωματική κατασκευή του προϊόντος.

- Η εγγύηση δεν καλύπτει τις βλάβες που προέρχονται από λάθη στην συναρμολόγηση ή την μη ορθολογική χρήση των επίπλων.
- Είναι απαραίτητο να κρατήσετε την **απόδειξη αγοράς** του προϊόντος και τον **αριθμό ποιοτικού ελέγχου (Q.C.)**, ώστε να διευκολύνετε οποιαδήποτε διαδικασία αίτησης ή συμβουλής χρειαστείτε.

No de Control de Calidad(Q.C.) :
Quality Control No (Q.C.)
No de Contrôle Qualité(Q.C.) :
No de Controle de Qualidade(Q.C.) :
No di Controllo Qualità (Q.C.):
Qualitätskontrollzahl (Q.C.):
Αριθμός Ποιοτικού Ελέγχου (Q.C.):



GUARDE ESTE NÚMERO
SAVE THIS NUMBER
SAUVEZ CE NUMÉRO
GARDE ESTE NÚMERO
CONSERVA QUESTO NUMERO
SPEICHERN SIE DIESE NUMBER
ΦΥΛΑΞΤΕ ΑΥΤΟΝ ΤΟΝ ΑΡΙΘΜΟ

Q.C.

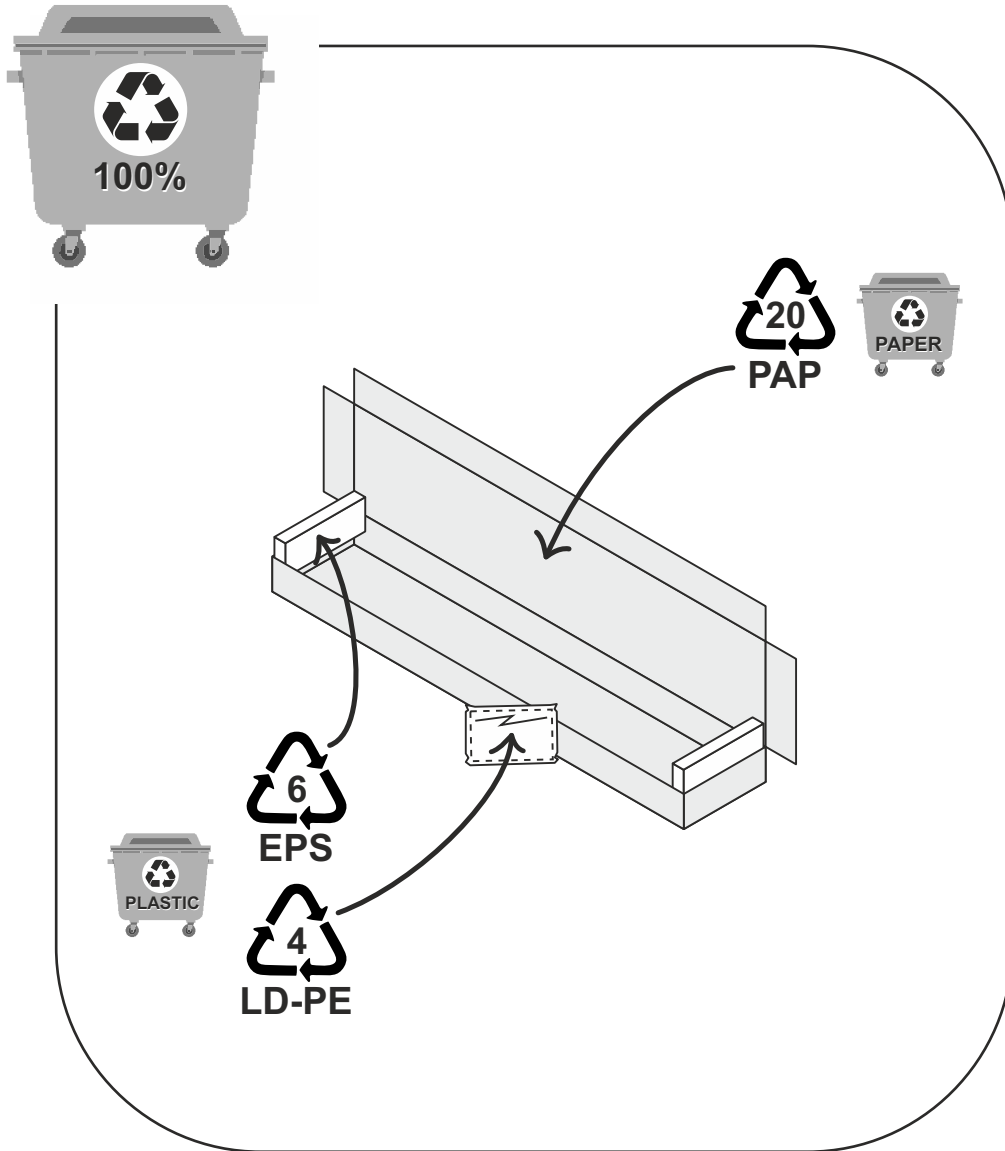

RAVENNA No1

MADE IN SPAIN

www.ravenna.gr

+30 216 070 1170

